

Emergency services guidelines

Information for the emergency services
Edition: July 2007



Rolls-Royce Aftersales

Contents

| | |
|--|-----------|
| Foreword | 5 |
| Essential information | 6 |
| Medical aspects | 6 |
| Technical aspects | 6 |
| Automatic emergency call | 6 |
| Response of the restraint and safety systems after an accident | 7 |
| Battery | 7 |
| Child restraint systems | 7 |
| Using radio equipment | 7 |
| Glazing | 7 |
| Complete overview of restraint and safety systems | 8 |
| Labelling of restraint and safety systems | 9 |
| Airbag systems | 9 |
| Driver airbag | |
| Passenger airbag | |
| Side airbag | |
| Head airbag | |
| Knee airbag | |
| Safety battery terminals | 9 |
| Belt tensioner | 9 |
| Active headrests | 9 |
| Diagram showing installation | 10 |
| Saloon | 10 |
| Convertible | 11 |
| Tips for using emergency equipment | 12 |
| Propping up vehicles | 12 |
| Electric seat adjustment | 12 |
| Opening vehicle doors | 13 |
| Forcing dashboard forwards | 14 |
| Securing vehicles | 15 |
| Wheel chock | |
| Continuous loop | |
| Front and rear axle | |
| Towing eye | |

Contents

| | |
|--|-----------|
| Technical information | 16 |
| Airbag | 16 |
| Use | |
| Driver airbag | |
| Passenger airbag | |
| Side airbag | |
| AITS head airbag | |
| Knee airbag | |
| Firing sequence | |
| Safety mechanisms | |
| Airbag control unit | |
| Satellites | |
| Belt tensioner | 20 |
| Pyrotechnic tensioner with end fitting | |
| Pyrotechnic belt tensioner | |
| Belt system integrated in seat (SGS) | |
| Active headrest | 23 |
| Function | |
| Rollover protection system | 24 |
| Safety battery terminals | 25 |
| Function | |
| Frequently asked questions | 26 |

Foreword

One of the main priorities of the products developed and realised by Rolls-Royce is optimum safety under all conditions. Rolls-Royce views safety as an integral issue as a result of which its active and passive safety systems are coordinated with precision to exceed statutory specifications and also take account of the technical requirements of the emergency services.

This approach also includes providing specific information about how to work with the Rolls-Royce restraint and safety systems as well as tips for using emergency equipment.

The main priority of the emergency services is to rescue the casualties without putting them or themselves at additional risk. It is therefore indispensable that trained members of the emergency services know how the safety systems function and are familiar with the vehicle characteristics.

We recommend using state-of-the-art emergency equipment as the materials and production methods used in the automotive industry are subject to ongoing developments.

Rolls-Royce Aftersales

Essential information

Both the medical and technical side of the emergency operation must be coordinated and the two aspects must dovetail.

Medical aspects

The first thing is to gain access (support opening) to the (locked in or trapped) people. As with all other methods used, the patients should be treated with all due care.

All efforts should be made to avoid dragging people out. The casualties should initially be left in the vehicle if they and emergency services are at no immediate risk.

Immediate life-saving measures and the initial examination (basic check) are usually carried out inside the vehicle. The medical treatment administered in the vehicle should be restricted to absolutely essential care. Depending on the injured person's condition, this may however be very extensive. The emergency doctor and/or emergency services staff should be allowed to access (provision of care opening) the casualty to allow immediate life-saving measures to be carried out.

Casualties should always be immobilised if necessitated by the pattern of injuries, i.e. using appropriate splints, before they are removed from the vehicle (rescue opening). The rescue opening should be of an adequate size and reflect the overall situation.

The casualties should receive continuous medical care during the technical stage of the rescue. As much of the technical emergency work as possible should be prepared while medical treatment is being given.

Exceptions which require a crash rescue

- Immediate risk from acute threat, e.g. fire or other accidents following the initial one
- Medical reasons

Technical aspects

- Identification of vehicle model
- Visual check to see what restraint and safety systems are fitted
- Special features on the vehicle body which may influence the use of hydraulic emergency equipment

Automatic emergency call

If a customer has taken out a service agreement for automatic emergency calls, when one of the airbags or the crash sensor is triggered the mobile phone fitted in the factory automatically places an emergency call with the service provider. It works in conjunction with the navigation system to do this.

The current vehicle position is transferred to the service provider by text message. The service provider attempts to call the phone number transferred. If this fails, the nearest emergency services are informed immediately and an emergency team organised.

If the service provider cannot be contacted, the general emergency hotline (112) is called to launch a response from the emergency services.

Essential information

Response of the restraint and safety systems after an accident

If the vehicle is stationary, the restraint systems will not normally be triggered.

Exceptions

- If the solid fuel in the gas generator (airbag) heats to above 200 °C
- If the airbag modules are subject to immense mechanical loads (sawing, drilling, grinding, welding)
- If the electric cables short circuit to activate the detonators
- If a stationary vehicle is struck by another vehicle (if the trigger criteria are satisfied, the restraint systems are triggered)

Battery

The safety battery terminals only disconnect the battery's positive cable between the battery and starter / generator.

- To de-energise the safety systems, turn off the ignition and separate **both** battery cables (first the negative and then the positive) from the batteries.

Attention

If the vehicle **cannot be de-energised:**

- Do not remain in the area in which the untriggered airbag may unfold and do not place material in this area if heavy emergency equipment is being used
- Wherever possible, treat casualties from the side

Child restraint systems

Passenger and side airbags can be deactivated when using child restraint systems. Stickers can be found near the airbag in question if this applies.

Using radio equipment

It is perfectly safe for walkie-talkies to be used close to restraint systems that have not been triggered.

Glazing

All the windows are made from composite panes of glass.

Complete overview of restraint and safety systems

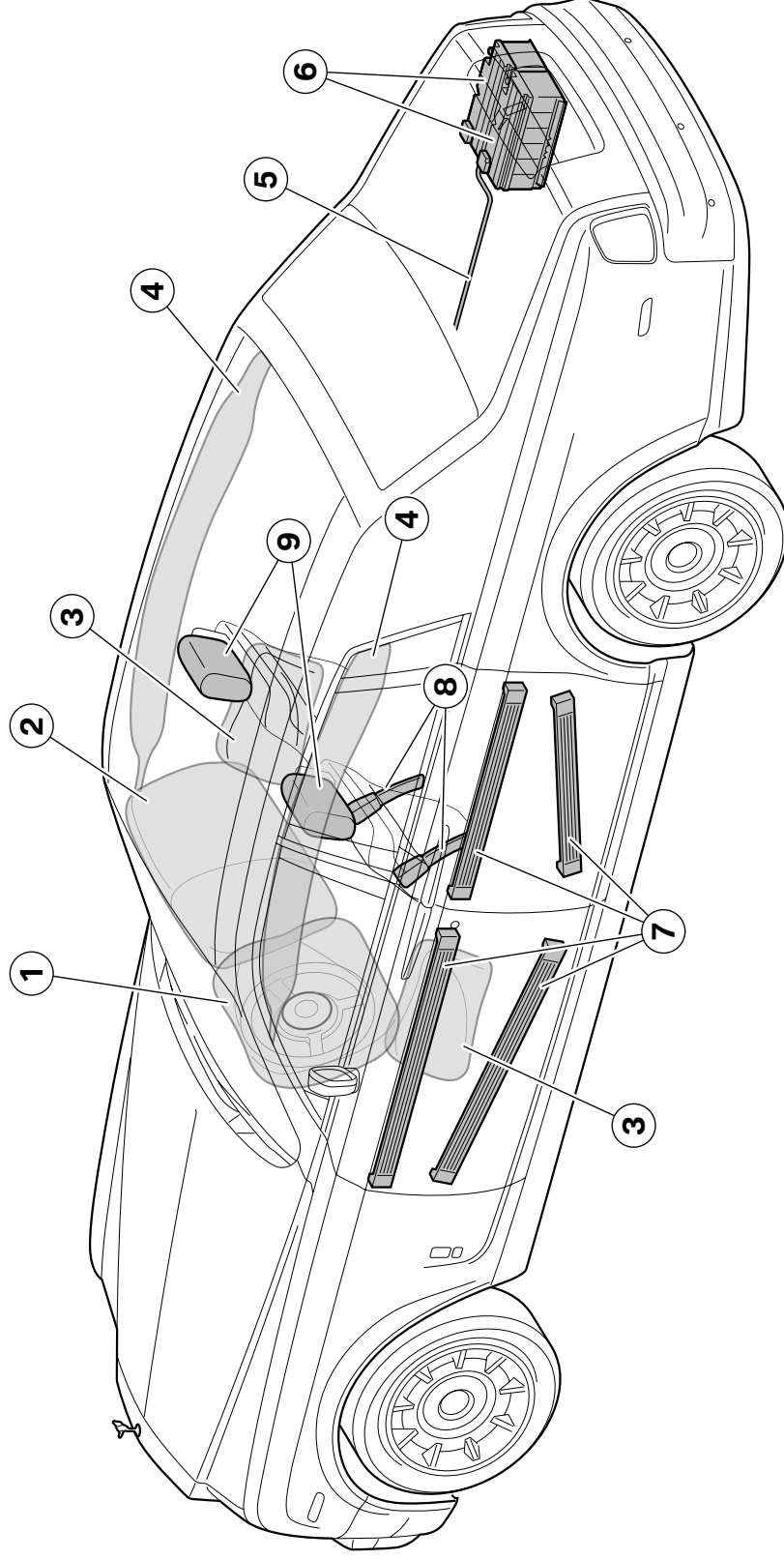

- 1 Driver airbag
- 2 Passenger airbag
- 3 Side airbag at front
- 4 Head airbag
- 5 Positive battery cable
- 6 Batteries
- 7 Side collision protection
- 8 Belt tensioner
- 9 Active headrest

Labelling of restraint and safety systems

Airbag systems

Driver airbag

The word AIRBAG appears on the steering wheel (steering wheel baffle plate)

Passenger airbag

The word AIRBAG appears on the instrument panel (passenger side)

Side airbag

The word AIRBAG appears on the front door trim near the door lock or on the seat

Head airbag

The word AIRBAG appears on the trim on the A and C pillar

Knee airbag

The word AIRBAG appears on the glove box lid (top right) and/or on the steering column trim (top left)

Safety battery terminals

No labelling

The safety battery terminals are fitted to the positive pins of the batteries.

The safety battery terminals' detonators must not be squashed, disconnected or heated.

Belt tensioner

No labelling

The vehicles contain three kinds of systems for reducing belt slack:

- Pyrotechnic automatic tensioner / tensioner with end fitting
- Pyrotechnic belt tensioners
- Belt system integrated in seat (SGS)

Active headrests

No labelling

The active headrests are integrated in the driver and passenger seats.

Active headrests that have not been triggered require no special attention.

Diagram showing installation

Saloon

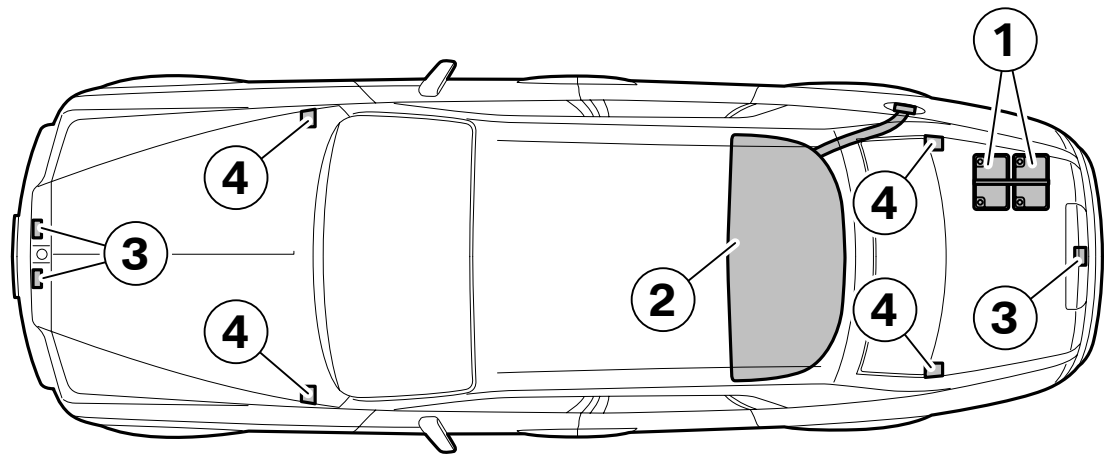

- 1 Batteries
The positive battery cable is a flat ribbon cable
- 2 Fuel tank
- 3 Engine bonnet and luggage compartment locks
- 4 Engine bonnet and luggage compartment hinges

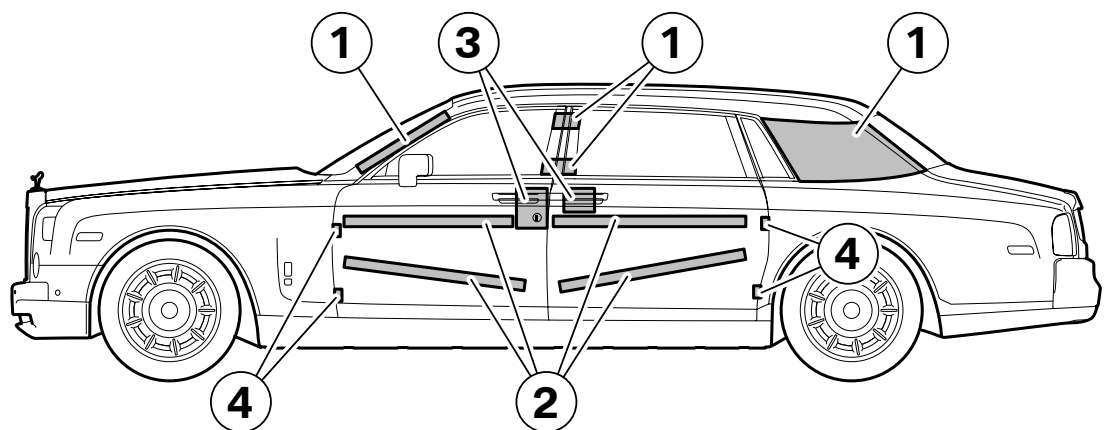

- 1 The numbers mark areas at which the roof can be disconnected
- 2 Side collision protection
- 3 Door locks
- 4 Door hinges

Diagram showing installation

Convertible

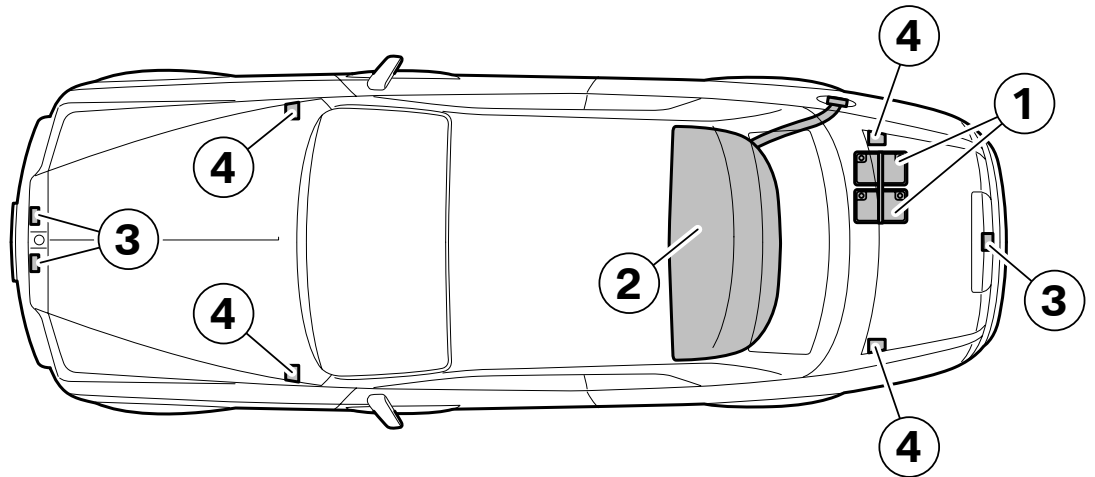

- 1 Batteries
The positive battery cable is a flat ribbon cable.
- 2 Fuel tank
- 3 Engine bonnet and luggage compartment locks
- 4 Engine bonnet and luggage compartment hinges

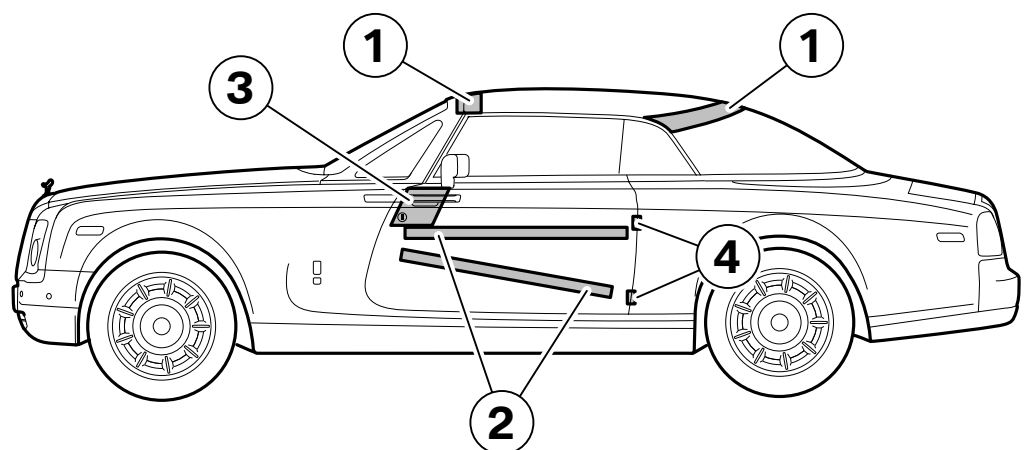

- 1 The numbers mark areas at which the roof can be disconnected.
- 2 Side collision protection
- 3 Door locks
- 4 Door hinges

Tips for using emergency equipment

Propping up vehicles

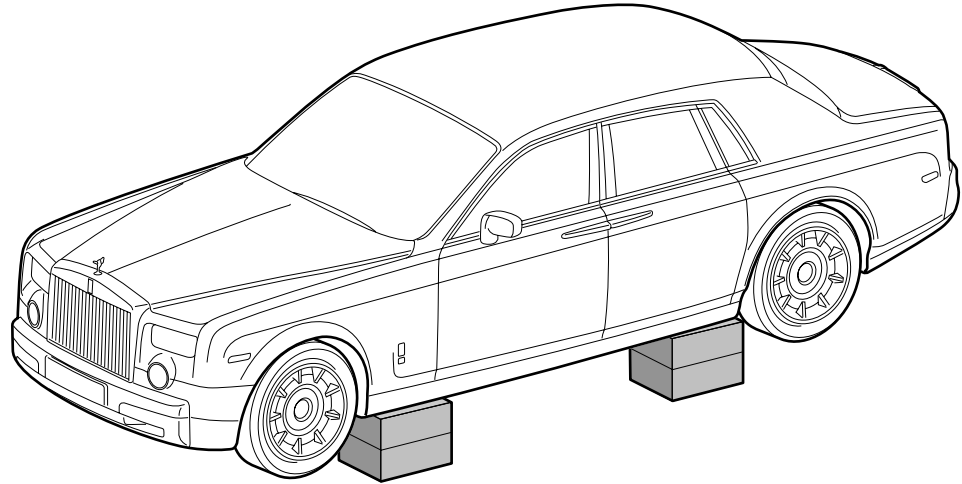

Example: Propping up vehicles

The vehicles can be propped up under the entire side skirt.

The precise location and number of points for propping up must be defined depending on the situation.

Ideally, the points intended for the jack should be used.

Electric seat adjustment

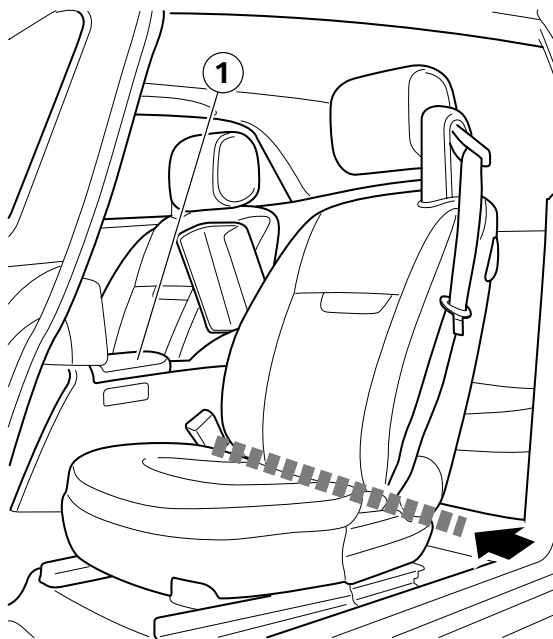

Seat with electric seat adjustment

Since the seats in vehicles with electric seat adjustment (1) cannot be adjusted once the battery has been disconnected, under certain circumstances we would recommend disconnecting in the area marked.

Tips for using emergency equipment

Opening vehicle doors

1st variant

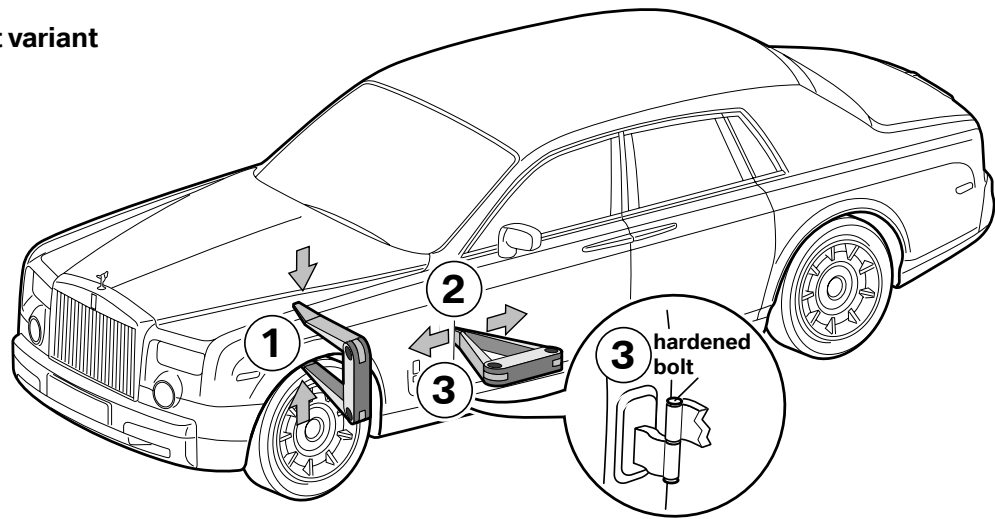

Starting points for opening the doors on the A pillar

- 1 Use the hydraulic emergency spreader to crush the wing. This will produce a gap between the wing and front door.
- 2 Then use the emergency spreader to increase the gap at the same height as the hinges (see diagram showing installation).
- 3 Use the hydraulic cutter to cut off the hinges and open the door. Alternatively, the hinges and/or bolts can also be forced open using the emergency spreader.

2nd variant

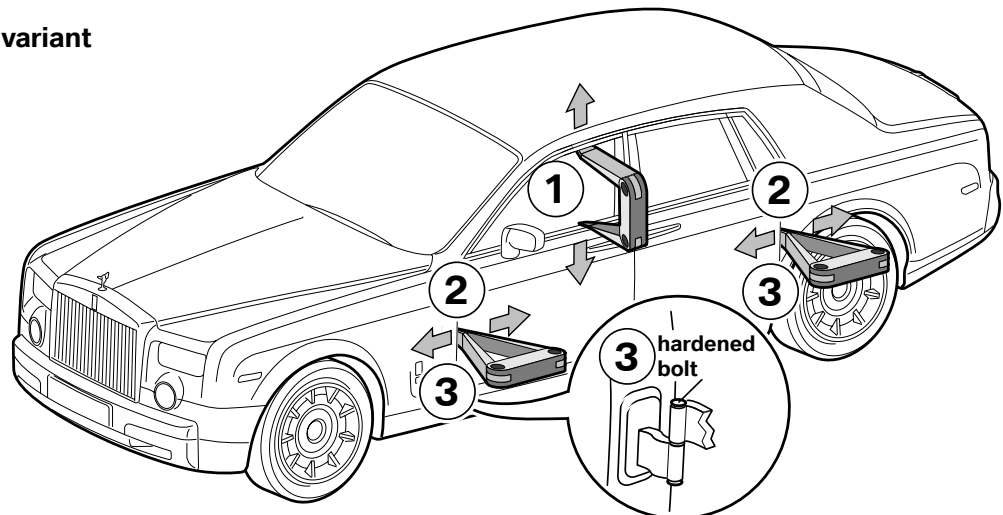

Starting points for opening the doors on the A and/or B pillar

- 1 Use the hydraulic emergency spreader to force the window apart. This produces a larger gap between the front door and B pillar and/or between the wing and front door.
- 2 Use the emergency spreader to increase the gap at the same height as the hinges (see diagram showing installation).
- 3 Then open the door at the hinge or lock side.

Tips for using emergency equipment

Forcing dashboard forwards

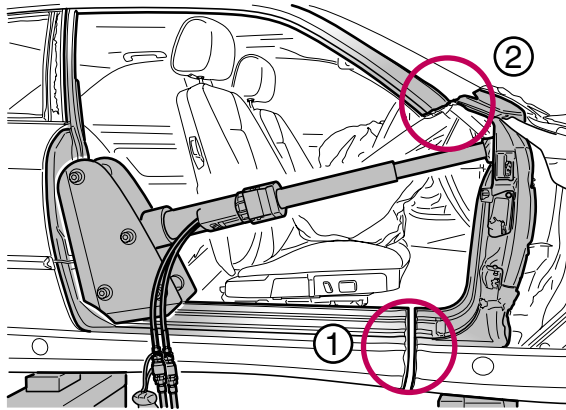

Forcing dashboard forwards

- Place material under the vehicle to prevent the base from caving in
- Use hydraulic shears to cut off door at hinges
- Use hydraulic shears to cut through side skirt (1) **downwards**, away from occupants
- Use hydraulic shears to cut through both A pillars (2)
- Attach support bracket to B pillar as shown
- Fit emergency cylinder between central mounting and dashboard under the cut if possible
- Push front section away

Attention

Emergency equipment may slide away too.

Note

If the emergency cylinder is too short, insert the support bracket horizontally.

Tips for using emergency equipment

Securing vehicles

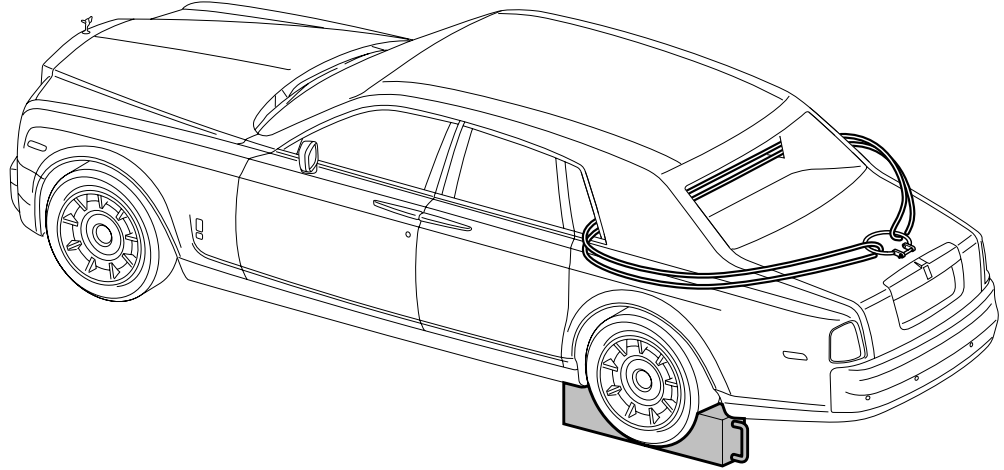

Example: Possible ways of securing vehicles

Wheel chock

Place wheel chock in front of and behind rear axle wheel on the side opposite that on which the vehicle will be raised.

Continuous loop

Secure the continuous loop to the rear or front by passing through the window openings and affix to a suitable end support.

Front and rear axle

When securing the vehicle, always combine several axle components (axle carrier, guides, drive shafts).

Towing eye

Attention

The towing eye must **not** be used to recover or secure the vehicle.

Technical information

Airbag

Use

Different airbag variants are used in Rolls-Royce vehicles to satisfy the different legislation applicable in Europe and the US:

- **Front airbag for driver I:** large air cushion fitted as part of the vehicle's standard equipment (the volumes used in the US and EU differ due to differing legislation)
- **Front airbag for driver II:** small air cushion (compact airbag; Eurobag) used in the vehicles equipped with a sports steering wheel
- **Front airbag for passenger:** air cushion located under the dashboard on the passenger side
- **Side airbag:** small air cushion located on the inner door frame (front doors) or in the outsides of the front seats
- **AITIS head airbag:** head airbag stretching from the A pillar to the C pillar; extended by a canvas between the airbag and roof frame
- **Head airbag at rear:** small air cushion in roof frame above C pillar
- **Knee airbag:** small air cushion, behind the glove box lid or behind the steering column trim (only available in the US version)

Driver airbag

Triggered driver airbag

The driver airbag is located in the steering wheel's impact absorber.



Acceleration is recorded and evaluated by a sensor. If the threshold for triggering is exceeded, the airbag control unit and/or the satellite responsible (= intelligent sensor) transmits a firing voltage to the detonator which then triggers the airbag. The gas created by firing escapes into the air sack which then unfolds in full.

Technical information

Passenger airbag

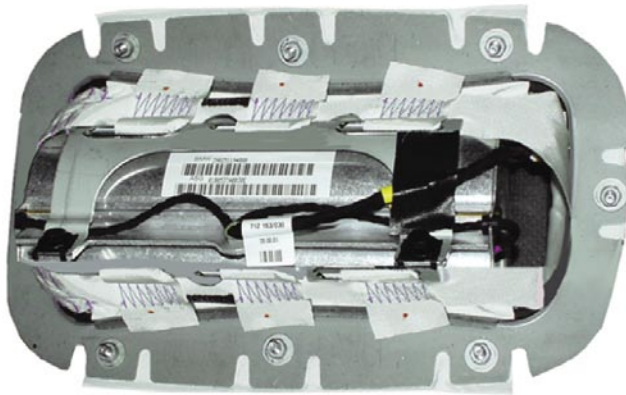

Passenger airbag that has not been triggered

The passenger airbag is located in the instrument panel above the glove box on the passenger side.

A seat occupation recognition feature has been integrated in the vehicle to prevent the passenger airbag from being unnecessarily triggered in the event of a crash when the passenger seat is not occupied.

Using sensors in the passenger seat and by evaluating data in the airbag control unit and/or in the satellite (= intelligent sensor), above a weight of 12 kg, the passenger seat is recognised as occupied and the system activated.

Side airbag

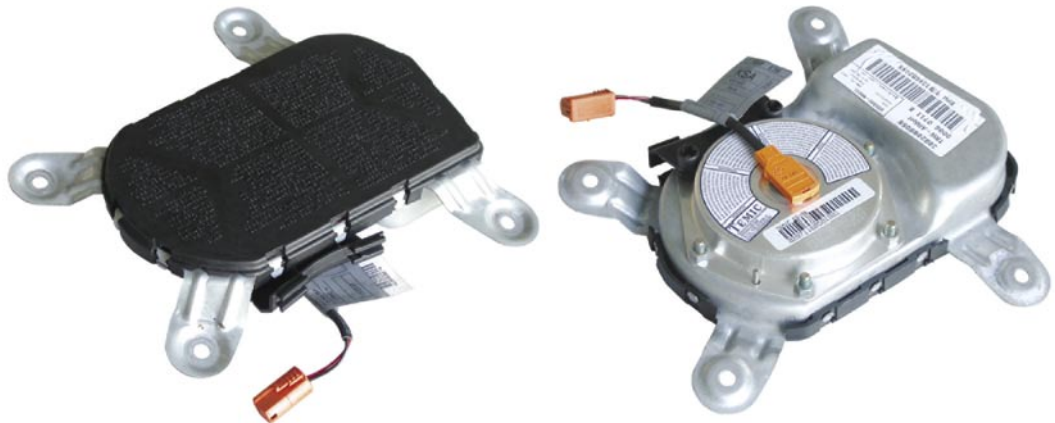

Side airbag that has not been triggered

The side airbags are located in the door behind the side trim.

In the event of side impact, the transverse acceleration experienced is recorded by sensors.

If the threshold for triggering is exceeded, the airbag control unit and/or satellites responsible (= intelligent sensors) fire the side airbags and also the head airbag.

Technical information

AITS head airbag



AITS for front and rear seat passengers (triggered)

When the generator is fired, the diameter of the head airbag increases, resulting in large-scale protection, similar to a curtain.

The AITS prevents the head and limbs from swinging back and forth. This means that the neck experiences lower shearing forces and there are fewer head injuries.

Unlike the front and side airbags that collapse relatively quickly after inflation, the head airbag retains its gas volume and therefore offers protection in the event of the vehicle rolling or secondary accidents.

The head airbag can be cut off or (safely) cut through at the seat belt straps.

System features:

- Extended area of coverage for front and rear side windows
- Protection from broken glass and penetrating objects
- Optimised area of coverage, even for very large occupants

Knee airbag



Knee airbag on driver side (left) and passenger side (right)

In the event of a collision when the driver or passenger is not wearing a seat belt, the knee airbag will support their knees.

This results in the upper body being shifted forwards in a controlled manner and being caught by another airbag.

The knee airbag on the driver side is located under the steering column, behind a cover.

The knee airbag on the passenger side is located in the lid of the glove box, behind a cover.

Technical information

Firing sequence

The airbag is triggered by the airbag control unit and/or the satellite responsible (= intelligent sensor).

When the trigger limit values are exceeded, the integrated sensors activate the systems needed; in the gas generator, the solid fuel of sodium azide or nitrocellulose combusts to form mainly nitrogen gas. Lower and lower volumes of carbon monoxide and nitrogen oxide are produced. This gas then flows into the air sack and unfolds it. As the air sack unfolds, the cover (impact absorber of driver airbag, cover of passenger airbag, trim of side/head airbag) tears off at the intended points of rupture.

The deposits of talcum powder from the air sack laid down in the passenger compartment are totally safe.

Safety mechanisms

The restraint and safety systems are triggered using electronic and mechanical acceleration sensors. Two sensors which function independently of one another **are needed to trigger** each airbag.

Electronic acceleration sensors

Driver and passenger airbag, head and side airbag, belt tensioner and safety battery terminal.

Mechanical acceleration sensor (safing sensor)

The driver and passenger airbags are triggered in conjunction with the mechanical acceleration sensors.

Electronic side crash sensors

Side and head airbags are triggered in conjunction with the electronic acceleration sensors.

Airbag control unit

The airbag control unit is the central unit in the entire restraint and safety system and undertakes the following tasks:

- Crash recognition
- Calculation of firing time for airbags, belt tensioner, safety battery terminal
- Firing of airbags, belt tensioner and safety battery terminal
- Self-test
- Error display and error memory with diagnosis capability
- Seat occupation and weight recognition for passenger seat

Satellites

Satellites consist of a control unit with integrated sensors for activating actuators (airbags, seat belt tensioners, etc.). Satellites are able to make intelligent decisions on selective and faster triggering of actuators. Any functions not needed are not activated.

The Intelligent Safety and Integration System (ISIS) is fitted.

Technical information

Belt tensioner

Four different belt tensioner systems are used in the vehicles:

- Pyrotechnic automatic tensioner / tensioner with end fitting
- Pyrotechnic belt tensioners
- Belt system integrated in seat (SGS)

All the systems have the same goal of reducing belt slack. This is the biomechanical load to which the human body is subjected after an accident.

Pyrotechnic tensioner with end fitting

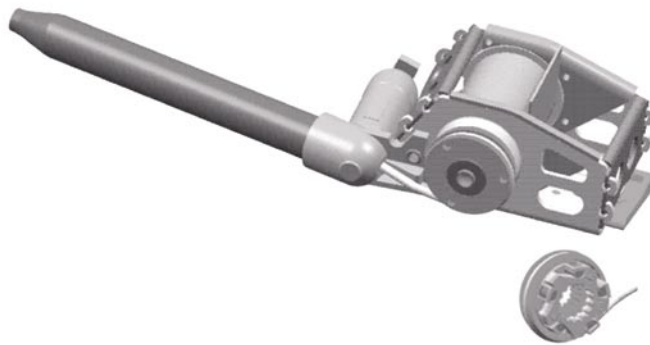

Pyrotechnic tensioner with end fitting

At present, pyrotechnic tensioners with end fittings can only be fitted on the outer seats in the rear of the vehicle.

Since there is little space under the rear seat, a solution similar to that of the standard belt tensioner is not possible. Belt slack is therefore overcome by drawing in the seat belt strap at the end fitting. The automatic belt unit forms the top point of attachment and the tensioner with end fitting the bottom one.

The tensioners with end fitting are fired by the seat satellites and/or the seat module, a pyrotechnic unit is responsible for tightening the safety belt.

Technical information

Pyrotechnic belt tensioner



Pyrotechnic belt tensioner

The pyrotechnic belt tensioner is the next stage in development work on the mechanic belt tensioner for even faster reduction of belt slack.

The pyrotechnic belt tensioners are fired by the airbag control unit and/or seat satellites, a pyrotechnic unit is responsible for tightening the safety belt.

Technical information

Belt system integrated in seat (SGS)



Belt system integrated in seat (SGS)

In the belt system integrated in the seat (SGS) all the belt elements, including the reversing points, are moved into the seats. In the event of a collision, all forces in vehicles without B pillars are absorbed by the undercarriage.

The headrest and top belt reversing point also automatically adjust depending on seat length adjustment.

A top seat belt strap tensioner fitted on the top belt exit point also restricts the amount by which the occupant moves forwards in the event of collision. The overall arrangement reduces the free seat belt strap lengths to a minimum.

Since all three belt points move with the seat adjustment, the belt geometry automatically produces the best possible way of enlacing the body regardless of seat position and body size.

Technical information

Active headrest



Active headrest

The active headrests are integrated in the driver and passenger seats.

Function

If the vehicle is involved in a rear impact crash, the head nods backwards because it becomes the most inactive part of the body as it is so far away from the headrest. This nodding movement may result in cervical injuries (whiplash).

If the vehicle is involved in a rear impact crash, the active headrest swings forwards towards the head to reduce the distance between the head and headrest.

Two additional crash sensors and/or satellites in the rear of the vehicle activate the gas generator in the backrest during a rear-end collision. The gas generator's piston rod moves a sliding piece. This sliding piece moves the supporting tube to which the headrest is attached forward and thereby reduces the distance between the head and headrest.

Depending on the height setting of the headrest, travel of 40 to 60 mm may result.

Technical information

Rollover protection system

The rollover protection system is an extra safety function. In the event of rollover or other situations that encourage the vehicle to roll over, the rollover protection system extends, locks positively and thereby helps maintain a large enough area for occupants to survive the rollover.

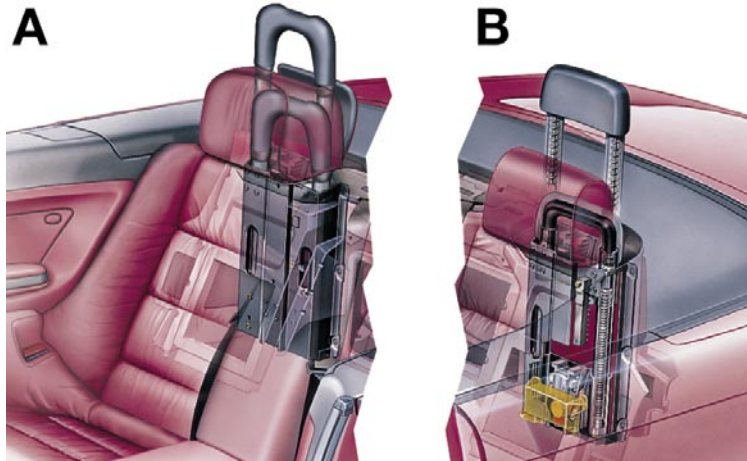

Triggered rollover protection system

The rollover protection system consists of two rollover bars in the headrests of the rear seats (fitted to be concealed).

The rollover protection system is a separate system and is not linked to the airbag control unit.

The rollover sensor is screw-mounted directly to the protective cover behind the bank of rear seats on the right.

The rollover sensor consists of:

- A level sensor to detect the vehicle's inclination, crosswise and lengthwise acceleration
- A g-sensor (g = gravitation) to detect loss of contact with the road surface
- Evaluation electronics with inbuilt diagnosis
- Two condensers to provide the reserve energy needed to trigger the protective bars should the onboard power supply fail

When the limit values are reached, the integrated rollover sensor issues a command to the actuator to release the locks. A solenoid actuates the lock and releases the spring-loaded rollover bar. The rollover bars are extended and mechanically locked in their limit position.

Safety battery terminals

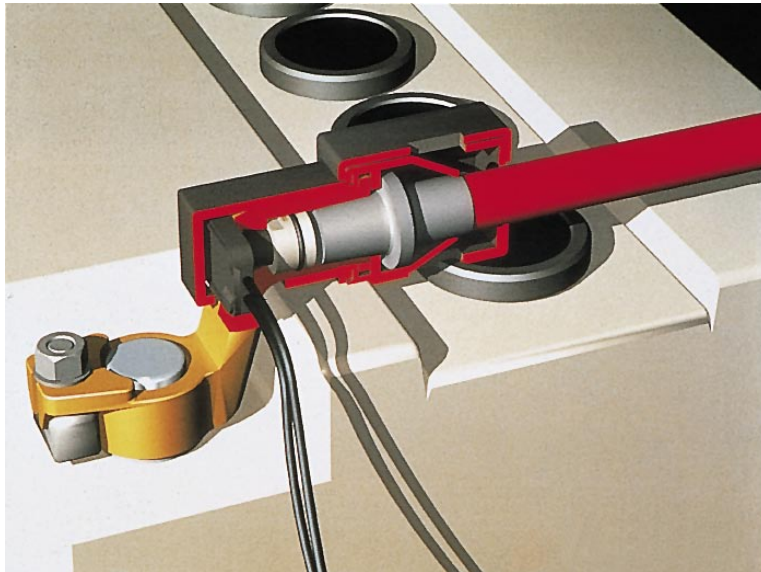

Safety battery terminal

Function

The two safety battery terminals are screwed directly onto the battery's positive pin.

To minimise the risk of short circuits during accidents, the onboard power supply in Rolls-Royce vehicles is split into two circuits: the onboard power supply section and starter circuit.

If the key criteria are satisfied during an accident, the airbag control unit and/or one of the satellites issues the command to fire the propelling charge in the safety battery terminals. The gas volume produced slides the cable pin out of the battery terminal bracket, thereby separating the cable connection between the batteries and starter / generator.

The other consumers continue to be supplied by their own connection to the batteries (onboard power supply section).

The total triggering process is complete in approx. 3 ms.

Attention

The safety battery terminal only disconnects the battery's positive cable between the battery and starter / generator. To de-energise the safety systems, both battery cables (first the negative and then the positive) must be separated from the batteries.

Frequently asked questions

How does an airbag work?

The acceleration recorded by the sensors is integrated and evaluated. Once the corresponding thresholds for triggering are exceeded, the airbags required are fired. The detonator in the gas generator obtains the firing voltage from the airbag control unit and/or relevant satellite. The gas produced escapes into the air sack.

How do I know whether a vehicle is fitted with airbags or not?

The word AIRBAG appears on the steering wheel, instrument panel, door trim and A pillar trim, C pillar, outside of backrest of driver and passenger seats. If in any doubt, assume that newer vehicles are equipped with an airbag.

Is smoke emitted during firing?

Dust is produced from the talcum powder applied to the air sack in the factory.

Does the airbag get hot?

The air sack doesn't get hot. Only the components inside the airbag module reach high temperatures after triggering. These components are near the airbag attachment and do not pose a risk to the emergency services. The parts need around 15 minutes to cool down.

Does the residue contain sodium azide?

Sodium azide, the solid fuel in the gas generator, combusts totally when firing the gas generator and is totally chemically converted. The product of the reaction is mainly safe nitrogen gas which makes up approx. 80 % of the air we breathe.

What precautions need to be taken if an airbag module is damaged but hasn't triggered?

In the extremely unlikely event that the airbag gas generator has been destroyed, the fuel (pressed into tablet form) could fall out. If this happens, avoid contact with the skin at all costs (wear gloves and protective goggles). The tablets must be treated and disposed of with extra care. They must be kept away from any source of ignition (electricity, fire etc.).

If the vehicle catches fire, is there a risk of the airbag generator exploding?

The gas generator is designed such that it will normally be triggered when subject to fire if the surface temperature of the generator exceeds 200°C.

Can water be used to put out the fire?

Yes. Any effective means of extinguishing the fire can be used, even in vehicles equipped with airbags.

Is it safe to inhale the air in the passenger compartment after an airbag has been triggered?

Yes. Chemical and medical analyses confirm that it is totally safe. You may however experience a tickly throat for a short period.

If the airbag has not been triggered during the crash, is it possible for it to trigger after the crash?

No. The crash sensors respond to the unique physical properties of an accident.

Frequently asked questions

Are first-aiders putting themselves at any risk?

No. A first-aider (a helper without emergency equipment) will not notice any differences from working in a normal vehicle. If the vehicle is stationary, the airbag systems are not triggered.

If the airbag has not been fired during the crash, how can the system be deactivated?

Turn off the ignition, disconnect **both** battery cables (first the negative and then the positive) from the battery.

This rules out the risk of the airbag triggering during the provision of emergency aid.

For exceptions, refer to the „Airbag“ section.

Should the emergency services wait for the airbag system to be deactivated before administering aid?

No. Turn off the ignition, disconnect **both** battery cables (first the negative and then the positive) from the battery.

If the points raised in „Response of the restraint and safety systems after an accident“ are noted, emergency aid can be given to the occupants straight away.

What should you do if people are trapped in the vehicle, individual airbag systems have not been triggered and the vehicle cannot be de-energised?

- Administer emergency medical aid immediately.
- Produce support openings as a priority.
- Check: which untriggered airbag systems does the vehicle have and where are they in relation to where the emergency service and recovery helpers are working?
- If at all possible, do not pull the steering column with the spreader.
- Do not disconnect any cables near the airbag systems (this will result in a small risk of the airbag being triggered by a short circuit).
- Secure the casualty if in the area in which an untriggered airbag would unfold.
- Attend to casualties from the side.
- Wherever possible, do not move your head or upper body into the area in which the airbag operates when people are working on the vehicle with heavy emergency equipment.
- Do not remain in or place material in the unfolding area of an untriggered airbag, especially when heavy emergency equipment is being used.

Can other emergency techniques be used?

Yes, the final decision on how the rescue is to take place always lies with the head of the technical emergency team and the emergency doctor or emergency services staff on site. They must reach agreement on how to proceed. The technical and tactical possibilities open to them, details of the accident and extent of vehicle destruction must also be taken into account.